

# **S650TX**

## ***Mini Skid Steer***

---

---

### ***Operator's Manual***



S650TX\_o1\_02  
Serial No. 101 -  
Order No. 105400BV8  
Cabled Assembly Order No. 296338951

# **Vermeer<sup>®</sup>**

# Introduction

This manual explains the proper operation of your machine. Study and understand these instructions thoroughly before operating or maintaining the machine. Failure to do so could result in personal injury or equipment damage. Consult your Vermeer dealer if you do not understand the instructions in this manual, or need additional information.

The instructions, illustrations, and specifications in this manual are based on the latest information available at time of publication. Your machine may have product improvements and features not yet contained in this manual.

Vermeer Corporation reserves the right to make changes at any time without notice or obligation.

**Operation instructions are included in the two Operator's Manuals provided with the machine.** The tethered (cabled) manual must remain attached to the machine for ready reference. Store it in the manual storage box when not in use.

**Lubrication and maintenance procedures are in the Maintenance Manual provided with the machine.** Refer to it for all lubrication and maintenance procedures.

Additional copies of the manuals, and Operations and Safety video, are available from your dealer. Reorder numbers are listed on the front covers of the manuals and on the video.

Copies of this manual, and the Operations and Safety video, are available in Spanish from your dealer.

Su distribuidor dispone de ejemplares en español de este manual y del vídeo de Operaciones y Seguridad.

## NOTICE TO OWNER

You are requested to notify Vermeer Corporation when you have purchased a **used** Vermeer machine. Notify the Customer Data Department by telephone: 800-829-0051 or 641-628-3141; email: [customerdata@vermeer.com](mailto:customerdata@vermeer.com); internet: [www.vermeer.com](http://www.vermeer.com) or [www.vermeerag.com](http://www.vermeerag.com); or letter: Customer Data Dept., Vermeer Corporation, PO Box 200, Pella IA 50219 USA. Upon request, an owner of a used Vermeer machine will receive one free set of Operator's, Maintenance and Parts manuals.



**Orientation:** Right and left sides of the machine are determined by standing on the operator platform and facing forward.

## **TRADEMARKS**

**VERMEER** and **VERMEER** Logo are trademarks of Vermeer Manufacturing Company.

**KUBOTA** is a trademark of Kubota, Ltd., Osaka, Japan.

**S650TX Mini Skid Steer**

**Introduction**

## VERMEER NEW INDUSTRIAL EQUIPMENT LIMITED WARRANTY

(EFFECTIVE OCTOBER 1, 2008)

**WARRANTY PERIOD: 12 Months / 1000 Hours**

Vermeer Corporation (hereinafter "Vermeer") warrants each new Industrial product of Vermeer's manufacture to be free from defects in material and workmanship, under normal use and service for one (1) full year after initial purchase/retail sale or 1000 operating hours, whichever occurs first. This Limited Warranty shall apply only to complete machines of Vermeer's manufacture, parts are covered by a separate Limited Warranty. **EQUIPMENT AND ACCESSORIES NOT OF VERMEER'S MANUFACTURE ARE WARRANTED ONLY TO THE EXTENT OF THE ORIGINAL MANUFACTURER'S WARRANTY AND SUBJECT TO THEIR ALLOWANCE TO VERMEER ONLY IF FOUND DEFECTIVE BY SUCH MANUFACTURER.**

**EXTENDED WARRANTY OPTIONS ARE AVAILABLE FOR PURCHASE.**

### **WARRANTY TERMS**

During the Limited Warranty period specified above, any defect in material or workmanship in any warranted item of Vermeer Industrial Equipment not excluded below shall be repaired or replaced at Vermeer's option without charge by any authorized independent Vermeer dealer. The warranty repair or replacement must be made by a Vermeer independent authorized dealer at the dealer's location. Vermeer will pay for replacement parts and such authorized dealer's labor in accordance with Vermeer's labor reimbursement policy. Vermeer reserves the right to supply remanufactured replacement parts as it deems appropriate.

**RETAIL PURCHASER RESPONSIBILITY:** This Limited Warranty requires proper maintenance and periodic inspections of the Industrial Equipment as indicated in the Operator's/Maintenance Manual furnished with each new Industrial Equipment. The cost of routine or required maintenance and services is the responsibility of the retail purchaser. The retail purchaser is required to keep documented evidence that these services were performed.

This Vermeer New Industrial Equipment Limited Warranty may be subject to cancellation if the above requirements are not performed.

Vermeer Industrial Equipment with known failed or defective parts must be immediately removed from service.

## **EXCLUSIONS AND LIMITATIONS**

The warranties contained herein shall **NOT APPLY TO:**

- (1) Any defect which was caused (in Vermeer's sole judgment) by other than normal use and service of the Industrial Equipment, or by any of the following; (i) accident (ii) misuse or negligence (iii) overloading (iv) lack of reasonable and proper maintenance (v) improper repair or installation (vi) unsuitable storage (vii) non-Vermeer approved alteration or modification (viii) natural calamities (ix) vandalism (x) parts or accessories installed on Industrial Equipment which were not manufactured or installed by Vermeer authorized dealers (xi) the elements (xii) collision or other accident.
- (2) Any Industrial Equipment whose identification numbers or marks have been altered or removed or whose hourmeter has been altered or tampered with.
- (3) Any Industrial Equipment which any of the required or recommended periodic inspection or services have been performed using parts not manufactured or supplied by Vermeer or meeting Vermeer Specifications including, but without limitation, engine tune-up parts, engine oil filters, air filters, hydraulic oil filters, and fuel filters.
- (4) New Industrial Equipment delivered to the retail purchaser in which the warranty registration has not been completed and returned to Vermeer within ten (10) days from the date of purchase.
- (5) Any defect which was caused (in Vermeer's sole judgment) by operation of the Industrial Equipment not abiding by standard operating procedures outlined in the Operator's Manual.
- (6) Engine, battery, and tire Limited Warranties and support are the responsibility of the respective product's manufacturer.
- (7) Transportation costs, if any, of transporting to the Vermeer dealer. Freight costs, if any, of transporting replacement parts to the Vermeer dealer.
- (8) The travel time of the Vermeer dealer's service personnel to make a repair on the retail purchaser's site or other location.
- (9) In no event shall Vermeer's liability exceed the purchase price of the product,
- (10) Vermeer shall not be liable to any person under any circumstances for any incidental or consequential damages (including but not limited to, loss of profits, out of service time) occurring for any reason at any time.
- (11) Diagnostic and overtime labor premiums are not covered under this Limited Warranty Policy. Oils and fluids are not covered under this Limited Warranty.

- (12) Depreciation damage caused by normal wear, lack of reasonable and proper maintenance, failure to follow operating instructions, misuse, lack of proper protection during storage.
- (13) Accessory systems and electronics not of Vermeer's manufacture are warranted only to the extent of such manufacturer's respective Limited Warranty if any.
- (14) Downhole toolage is not covered under this warranty.
- (15) Wear items which are listed by product group as follows:

**ENVIRONMENTAL:** Bearing Seals, Bearings, Belts, Brake Pads, Bolts/Torqued Parts, Chain, Clutches, Clutch Components, Curtains, Cutter Wheels, Discharge Conveyor Belts, Fuel Filters, Hammers, Hoses, Infeed Conveyor Belts, Infeed Conveyor Chains, Knives, Oil Filters, Pockets, Rods, Rollers, Rotor Plates, Screens, Service Items, Shear Bar/Bedknife, Sprockets, Teeth, Wear Blocks, Wear Strips.

**TRACK:** Base Plates, Boom Wear Items, Buckets, Cable Fingers, Conveyor Belts, Clutches, Cups, Digging Chain, Digging Rims, Drums, End Idler, Flashings, Pins and Bushings, Pivot Rings, Plastic Wear Strips, Rooter Bands, Scraper Knives, Sprockets, Teeth, Track Chain, Track Rollers, Trench Cleaner (Crumber), Trip Cleaners, Truck Rollers, Wear Plates.

**TRENCHLESS:** Brushes, Clamping Vise Parts, Dies, Drive Chuck, Earth Stakes, Fan Belts, Jaws, Leaf Chain, Lights On Light Kits, Packing Assemblies, Rod, Rod Loader Parts, Rollers, Tooling, Track Chain, Track Guides, Track Idlers, Track Pads, Track Sprockets, Valve Seats, Wear Bars, Wear Blocks, Water Hoses, Water Swivels, Wear Bars.

**UTILITY PRODUCTS:** Augers, Belts, Bearings, Booms, Brake Pads, Bucket, Bushings, Chains, Clutches, Conveyor Belts, End Rollers, Flashings, Pins, Pivot Rings, Plow Blades, Rubber Shielding, Sprockets, Teeth, Tires, Track Chain, Track Idlers, Track Sprockets, Trench Cleaner (Crumber).

### **PARTS WARRANTY:**

Parts replaced in the warranty period will receive the balance of the first year New Industrial Equipment Limited Warranty, during the first (12) months or 1000 hours, whichever comes first. Replacement parts after the original machine warranty, are warranted to be free from defects of material for ninety (90) days or the part will be repaired or replaced, without labor coverage for removal and reinstallation.

**EXCLUSIONS OF WARRANTIES: EXCEPT FOR THE WARRANTIES EXPRESSLY AND SPECIFICALLY MADE HEREIN, VERMEER MAKES NO OTHER WARRANTIES, AND ANY POSSIBLE LIABILITY OF VERMEER HEREINUNDER IS IN LIEU OF ALL OTHER WARRANTIES, EXPRESS, IMPLIED, OR STATUTORY, INCLUDING, BUT NOT LIMITED TO, ANY WARRANTIES OF MERCHANTABILITY OR FITNESS FOR A PARTICULAR PURPOSE. VERMEER RESERVES THE RIGHT TO MODIFY, ALTER AND IMPROVE ANY PRODUCT WITHOUT INCURRING ANY OBLIGATION TO REPLACE ANY PRODUCT PREVIOUSLY SOLD WITH SUCH MODIFICATION. NO PERSON IS AUTHORIZED TO GIVE ANY OTHER WARRANTY, OR TO ASSUME ANY ADDITIONAL OBLIGATION ON VERMEER'S BEHALF.**

**NO DEALER WARRANTY.** The selling dealer makes no warranty of its own and the dealer has no authority to make any representation or promise on behalf of Vermeer or to modify the terms or limitations of this warranty in any way.

**MANUFACTURED BY:  
VERMEER CORPORATION  
Pella, Iowa 50219 USA**

# VERMEER EQUIPMENT LIMITED WARRANTY RIDER COMPACT SKID STEER FRAME AND LOADER ARMS

**3,000-Hour / 3-Year\***

## **(Parts only coverage during extended term)**

**Vermeer Corporation** (hereinafter “Vermeer”) agrees to extend only the parts coverage of the applicable Vermeer Industrial New Equipment Limited Warranty (the “Standard Limited Warranty”) for the Covered Components of the Specified Models of New Vermeer Industrial Equipment for the Extended Term, provided that the Equipment is operated and maintained in accordance with the directions and instructions set forth in the Operator's and Maintenance Manual(s). All conditions, exclusions and limitations of the Standard Limited Warranty apply.

**Specified Models:** **S600, S600TX, S650TX**

**Covered Equipment:** Tractor main frame and boom loader arms.

**Non-Covered Components:** Greaseable pins, mounting plates and wear items (as specified on the Vermeer New Industrial Equipment Limited Warranty).

**Extended Term\*:** Three (3) full years from original retail sale date of the Equipment or 3,000 hours of machine operation, whichever occurs first. This warranty is extended to the original purchaser and subsequent owners.

**EXCEPT FOR THE STANDARD LIMITED WARRANTY AND THIS RIDER, VERMEER MAKES NO OTHER WARRANTIES, AND ANY POSSIBLE LIABILITY OF VERMEER HEREUNDER IS IN LIEU OF ALL OTHER WARRANTIES, EXPRESS, IMPLIED, OR STATUTORY, INCLUDING, BUT NOT LIMITED TO, ANY WARRANTIES OF MERCHANTABILITY OR FITNESS FOR A PARTICULAR PURPOSE.**



# Receiving and Delivery Report

## DEALER PREP

Check or perform the following:

- \_\_\_ Check that all optional and loose items are included with the machine.
- \_\_\_ Check that Operator's Manual is cabled to machine.
- \_\_\_ Check air cleaner condition.
- \_\_\_ Check engine oil level.
- \_\_\_ Check engine operation.
- \_\_\_ Check machine lubrication.
- \_\_\_ Check bolts for tightness.
- \_\_\_ Check shield installation and condition.
- \_\_\_ Check that auxiliary attachment drive neutral start interlock functions.
- \_\_\_ Check that *Ground Drive Joystick* and *Tilt/Lift Joystick* spring-return to NEUTRAL.
- \_\_\_ Check that Operator Presence system functions.
- \_\_\_ Check that machine does not move when controls are in NEUTRAL and the engine is running at full throttle (operator standing on foot platform).
- \_\_\_ Check that attachment does not tilt with key in OFF position and tilt lever pushed.
- \_\_\_ Check that loader arms do not lower with key in OFF position and lift lever pushed.
- \_\_\_ Check forward and reverse ground drive operation.
- \_\_\_ Check that park brake functions.
- \_\_\_ Check track tension.
- \_\_\_ Check condition of all safety signs and decals.
- \_\_\_ Check all phases of operation.

## Hydraulics

- \_\_\_ Check hydraulic fluid level.
- \_\_\_ Check hydraulic components for leaks or damage.
- \_\_\_ Check hydraulic controls for proper function.

## Attachments

- \_\_\_ Check that Operator's Manuals supplied by the attachment manufacturer are in the S650TX manual storage box or in the storage box located on the attachment. Bucket attachment instructions are contained in this S650TX Operator's Manual. Contact your authorized Vermeer dealer, or visit [www.vermeer.com](http://www.vermeer.com) for information on attachments authorized for use by Vermeer Corporation.

## DELIVERY

Check and perform the following with the customer:

- \_\_\_ Review all sections of the Operator's Manual.
- \_\_\_ Grease or oil all lubrication points.

## Review of Operation

Review and demonstrate with the customer the various aspects of machine operation:

- \_\_\_ overall explanation of how the machine works
- \_\_\_ machine safety
- \_\_\_ preparing the machine for operation
- \_\_\_ operating the machine

# DEALER/CUSTOMER INFORMATION

---

Dealer

---

Owner

---

Address

---

Address

---

City

---

City

---

State/Province

---

State/Province

---

Zip/Postal Code

---

Zip/Postal Code

---

Country

---

Country

## IDENTIFICATION NUMBERS - RECORD

Machine Model Number \_\_\_\_\_

Machine Serial Number \_\_\_\_\_

Engine Model Number \_\_\_\_\_

Engine Serial Number \_\_\_\_\_

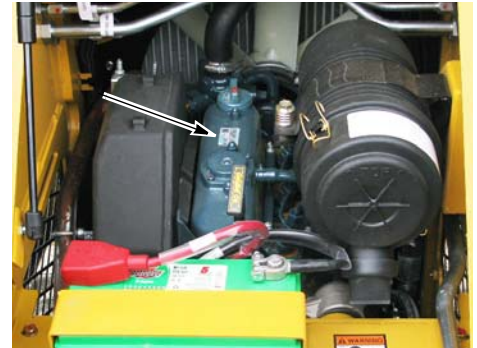

## IDENTIFICATION DECALS

These decals provide easy identification of the model and 17-digit identification number for the machine and attachments. The barcode contains the VIN number and can be scanned with any barcode reading device.

Mini Skid Steer Identification Decal



This page intentionally left blank.

# Table of Contents

|  |             |                                       |             |
|--|-------------|---------------------------------------|-------------|
| <b>Receiving and Delivery Report</b> .....       | <b>i</b>    | <b>Starting Procedure</b> .....       | <b>22-1</b> |
| Dealer Prep .....                                | i           | Starting the Engine .....             | 22-1        |
| Hydraulics .....                                 | ii          | Cold Weather Starting .....           | 22-2        |
| Attachments .....                                | ii          | Engine .....                          | 22-2        |
| Delivery .....                                   | ii          | Hydraulic Fluid .....                 | 22-2        |
| Review of Operation .....                        | ii          | Jump-Starting .....                   | 22-2        |
| Dealer/Customer Information .....                | iii         | Battery Explosion - Avoid .....       | 22-3        |
| Identification Numbers - Record .....            | iv          | Battery Burns - Avoid .....           | 22-3        |
| Identification Decals .....                      | v           | Jump-Starting Procedure .....         | 22-4        |
| <br>   |             |                                       |             |
| <b>Safety Messages</b> .....                     | <b>10-1</b> | <b>Shutdown Procedure</b> .....       | <b>23-1</b> |
| Safety Symbol Explanation .....                  | 10-2        |                                       |             |
| Crystalline Silica .....                         | 10-6        |                                       |             |
| <br>   |             |                                       |             |
| <b>Intended Use</b> .....                        | <b>20-1</b> |                                       |             |
| <br>   |             |                                       |             |
| <b>Controls</b> .....                            | <b>21-1</b> | <b>Transporting the Machine</b> ..... | <b>30-1</b> |
| Engine Controls .....                            | 21-1        | Loading/Unloading the Machine .....   | 30-1        |
| Indicator Lights .....                           | 21-3        | Trailer Selection .....               | 30-1        |
| Control Station .....                            | 21-4        | Trailer Preparations .....            | 30-1        |
| Operator Presence System .....                   | 21-7        | Loading/Unloading .....               | 30-2        |
| Park Brake .....                                 | 21-7        | Driving onto Trailer .....            | 30-3        |
| Boom Lift/Attachment Tilt Lockout Override ..... | 21-7        | Driving off Trailer .....             | 30-5        |
| Fuses and Relays .....                           | 21-8        | Loading with Crane .....              | 30-6        |
|  |             | Towing the Machine .....              | 30-6        |
|  |             | Clean Machine .....                   | 30-8        |
|  |             |                                       |             |
|  |             | <b>Preparation</b> .....              | <b>40-1</b> |
|  |             | Operator Qualifications .....         | 40-1        |
|  |             | Personal Protection .....             | 40-2        |
|  |             | Sound Levels .....                    | 40-3        |

|   |       |
|---|-------|
| Vibration Levels .....                          | 40-3  |
| Prepare the Area .....                          | 40-4  |
| Locate Buried Utilities .....                   | 40-4  |
| Call Your One-Call System First.....            | 40-4  |
| Look for Evidence of Underground Placement..... | 40-5  |
| Striking a Utility .....                        | 40-6  |
| Electricity .....                               | 40-6  |
| Gas .....                                       | 40-6  |
| Fiber Optic .....                               | 40-6  |
| Jobsite Assessment.....                         | 40-7  |
| Prepare the Machine .....                       | 40-8  |
| Attachments .....                               | 40-9  |
| Install/Remove .....                            | 40-9  |
| Attachment - Install .....                      | 40-10 |
| Attachment - Remove .....                       | 40-11 |
| Hydraulics - Attach/Detach .....                | 40-12 |
| Hydraulics - Attach .....                       | 40-13 |
| Hydraulics - Detach .....                       | 40-13 |

## **Operating the Machine ..... 50-1**

|                                    |      |
|------------------------------------|------|
| Load Capacities .....              | 50-1 |
| Driving Safety .....               | 50-1 |
| Before Driving .....               | 50-1 |
| While Driving .....                | 50-2 |
| Safe Operating on Slopes .....     | 50-4 |
| Operating the Mini Skid Steer..... | 50-6 |
| Bucket Operation .....             | 50-7 |
| Bucket - Install/Remove.....       | 50-7 |
| Safety Precautions .....           | 50-7 |
| Moving Machine with Load .....     | 50-8 |

|  |       |
|--|-------|
| Filling the Bucket.....                                | 50-9  |
| Digging with the Bucket.....                           | 50-9  |
| Emptying the Bucket.....                               | 50-10 |
| Backdragging with the Bucket.....                      | 50-10 |
| Backfilling with the Bucket.....                       | 50-11 |
| Operating with Other Vermeer-Authorized Attachments .. | 50-11 |

## **Maintenance Intervals..... 60-1**

|  |      |
|--|------|
| Safety Signs Maintenance .....                   | 60-1 |
| Maintenance Manual .....                         | 60-2 |
| Hourmeter - Check for Maintenance Interval ..... | 60-2 |
| Machine - Grease.....                            | 60-2 |
| Recommended Fluids .....                         | 60-2 |
| Engine Maintenance Intervals .....               | 60-2 |
| Lift Arm Support Bar - Install/Remove .....      | 60-3 |
| Shields - Install/Remove .....                   | 60-4 |
| Maintenance Interval Schedule .....              | 60-5 |
| Attachment Maintenance.....                      | 60-7 |



# Section 10: Safety Messages

General safety messages appear in this Safety Messages section. Specific safety messages are located in appropriate sections of the manual where a potential hazard may occur if the instructions or procedures are not followed. Messages that are specific to an attachment will be found in the attachment manual.

A signal word “**DANGER**”, “**WARNING**”, or “**CAUTION**” is used with the safety alert symbol.

Safety signs with signal word “**DANGER**”, “**WARNING**”, or “**CAUTION**” are located near specific hazards.

|                |   |
|----------------|---|
| <b>DANGER</b>  | Indicates a hazardous situation that, if not avoided, will result in death or serious injury.   |
| <b>WARNING</b> | Indicates a hazardous situation that, if not avoided, could result in death or serious injury.  |
| <b>CAUTION</b> | Indicates a hazardous situation that, if not avoided, could result in minor or moderate injury. |

## SAFETY SYMBOL EXPLANATION



This is the safety alert symbol. This symbol is used in combination with an exclamation mark or other symbols to alert you to the potential for bodily injury or death.

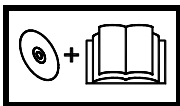

**WARNING:** Read Operator's Manual and safety signs, and watch the operations and safety video, before operating machine.

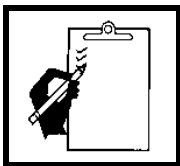

**WARNING:** Check machine before operating. Machine must be in good operating condition and all safety equipment installed and functioning properly.

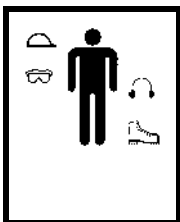

**WARNING:** Wear personal protective equipment. Wear close-fitting clothing and confine long hair. Avoid wearing jewelry such as rings, wristwatches, necklaces or bracelets. Always wear:

- a hard hat
- safety glasses
- hearing protection
- safety shoes

Refer to "Personal Protection," [page 40-2](#).

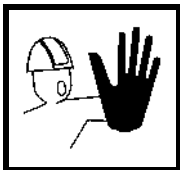

**WARNING:** Keep spectators away.



**WARNING:** Engine exhaust can asphyxiate. Operate only outdoors.

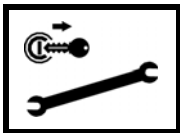

**WARNING:** Use Shutdown Procedure before servicing, cleaning, repairing, or transporting machine. Follow [Shutdown Procedure](#), page 23-1.



**WARNING:** Pressurized fluid can penetrate body tissue and result in serious injury or death. Leaks can be invisible. Keep away from any suspected leak. Relieve pressure in the hydraulic system before searching for leaks, disconnecting hoses, or performing any work on the system. If you must pressurize the system to find a suspected leak, use an object such as a piece of wood or cardboard rather than your hands. When loosening a fitting where some residual pressure may exist, slowly loosen the fitting until oil begins to leak. Wait for leaking to stop before disconnecting the fitting. Fluid injected under the skin must be removed immediately by a surgeon familiar with this type of injury.

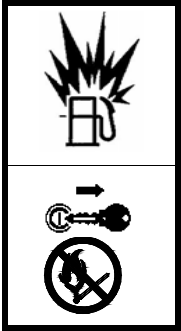

**WARNING:** Fuel and fumes can explode and burn.

Shut off engine before refueling. No flame. No smoking.



**WARNING:** Moving parts can crush. Keep hands, feet, and clothing away from power-driven parts. Keep shields in place and properly secured.

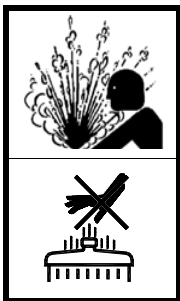

**WARNING:** Hot fluid under pressure can scald.

Allow engine to cool before opening radiator cap.

## CRYSTALLINE SILICA



**WARNING:** Silica dust can cause illness.

Breathing crystalline silica dust over time can cause silicosis, a disabling, nonreversible and sometimes fatal disease of the lungs. United States Federal O.S.H.A. has established exposure limits for the jobsite. Avoid exposure to dust containing crystalline silica particles in excess of these limits.

Because crystalline silica is a basic component of sand and granite, many activities at construction sites such as trenching, sawing, and boring of material, produce dust containing crystalline silica. When working in soils containing sand or granite, air monitoring may be necessary to determine whether jobsite conditions expose workers to excessive levels of crystalline silica dust. Depending upon air monitoring results, the following measures may be necessary to avoid exposure to excessive levels of crystalline silica dust:

- Be aware of and follow the guidelines of United States O.S.H.A. 29CFR1926.55, or other applicable regulatory guidelines.
- Reduce dust concentration using water spray or other methods.
- Use a respirator approved for protection from crystalline silica dust.
- If possible, change into disposable or washable work clothes on the jobsite. Shower and change into clean clothing before leaving the jobsite.
- Do not eat, drink, use tobacco products, or apply cosmetics in areas where there is dust containing crystalline silica dust. Wash hands before eating, drinking, or using these products.
- Store food, drink, and personal belongings away from the work area.



**WARNING: Failure to follow any of the preceding safety instructions or those that follow within this manual, could result in serious injury or death. This machine is to be used only for those purposes for which it was intended as explained in this Operator's Manual.**

---

This page intentionally left blank.



## Section 20: Intended Use

The S650TX Mini Skid Steer can be equipped with a variety of attachments for light and medium duty work. This machine is designed for short runs and operation in confined areas. The stand-up operating station provides excellent jobsite visibility and ease of platform access. Contact your Vermeer dealer, or visit [www.vermeer.com](http://www.vermeer.com), for information on the list of authorized attachments. The S650TX must not be used with attachments which have not been evaluated by Vermeer Corporation and authorized for use.



---

**WARNING:** Using attachments authorized by Vermeer Corporation is important for your safety. Using unauthorized attachments may cause difficulties with steering, stopping, stability and other undesirable performance or handling characteristics. Never use unauthorized attachments.

---

Always use this machine in accordance with the instructions contained in this manual and the attachment manuals supplied with the attachments; safety signs on the machine and attachments, and other materials provided by Vermeer Corporation and the attachment manufacturers.

Proper maintenance and repair is essential for safety, and efficient machine operation. Do not use the machine if it is not in suitable operating condition.

In addition, ensure new operator is familiar with all the safety signs and control operations.

This page intentionally left blank.

# Section 21: Controls

## ENGINE CONTROLS

### (1) Ignition Switch

Counterclockwise . . . . . accessories  
Low engine oil pressure light also comes on in accessories position.

Vertical . . . . . engine STOP

1st position clockwise . . . . . engine RUN  
Electrical system on

2nd position clockwise . . . . . engine START  
Returns to RUN when released

### (2) Throttle Lever



Push forward . . . . . increase engine speed



Pull back. . . . . decrease engine speed



**(3) 12V DC Auxiliary Electrical Outlet**

12V available in Key ACC and Key RUN positions.

**(4) Glow Plug Button**

Turn ignition key to RUN position, then press *Glow Plug Button* and hold for 10–15 seconds. Continue to hold button while starting engine.

Use Glow Plug Button when ambient temperature is below 50°F (10°C).

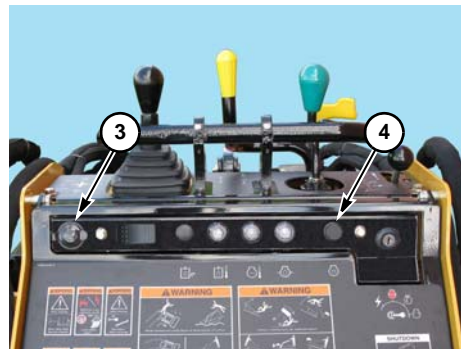

**(5) Hourmeter**

Indicates total number of hours key has been in RUN position.

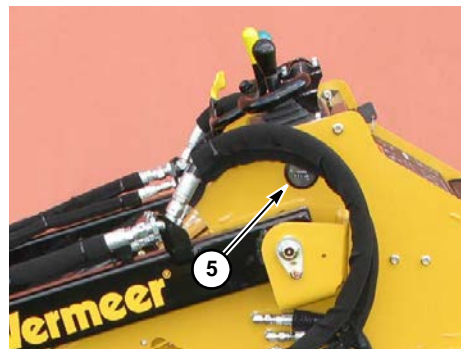
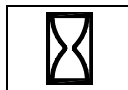

## INDICATOR LIGHTS

### (1) High Hydraulic Oil Temperature Indicator Light

Light turns on when hydraulic oil becomes too hot. If light turns on during operation, shut off engine and correct the problem.

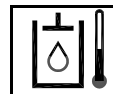

### (2) High Engine Temperature Indicator Light

Light turns on when engine temperature is too high. If light turns on during operation, shut off engine and correct the problem.

Engine will shut down when High Engine Temperature Indicator Light comes on and will not restart until engine cools down enough for the light to turn off.



### (3) Low Engine Oil Pressure Indicator Light









Light indicates low engine oil pressure and comes on when the ignition switch is initially turned ON. If the light does not shut off within 30 seconds after starting the engine or comes on during normal operation, shut off the engine and correct the problem.



# CONTROL STATION

Handgrip bar (A) enables the operator to keep both hands on the bar to remain secure during machine travel and operation. The handgrip bar also provides a steady rest for smooth control of joysticks.

## (1) Left Joystick - Ground Drive Controls

-  Forward ..... variable speed forward
-  Back ..... variable speed reverse
-  Left ..... counter-rotate left
-  Right ..... counter-rotate right
-  Forward left ..... steers left when moving forward
-  Forward right ..... steers right when moving forward
-  Back left ..... front turns left when moving in reverse
-  Back right ..... front turns right when moving in reverse

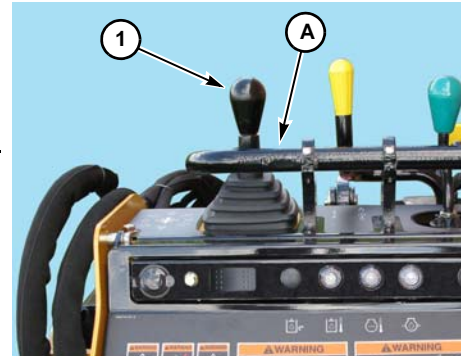
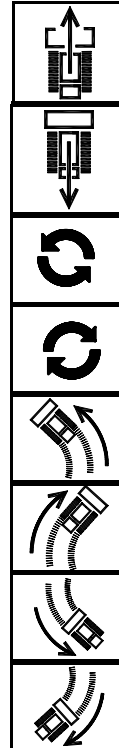

**Steering Operation:**  
 Front of machine moves sideways in same direction as control lever is moved when traveling both FORWARD and REVERSE.

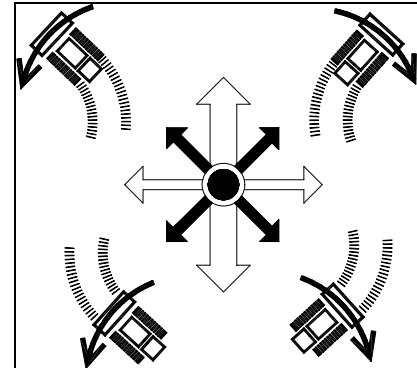

**(2) Auxiliary Attachment Drive Lever**

Lever is detented in full-forward and full-reverse positions. Lever must be in NEUTRAL for engine to start. Maximum hydraulic flow through this valve is approximately 13.8 gpm (52.2 L/min) at 2756 psi (190 bar).

Lever extension (2A) allows operator to move the control without releasing right joystick.

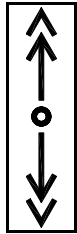

Forward . . . . . oil flows to attachment through female coupler

Center . . . . . OFF

Back . . . . . oil flows to attachment through male coupler

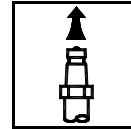
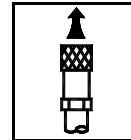
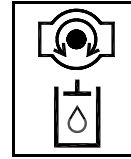

### (3) Right Joystick - Lift/Tilt Controls



Forward ..... lower boom



Forward to detent ..... boom FLOAT



Back ..... raise boom



Right ..... tilt attachment forward

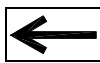

Left ..... tilt attachment back

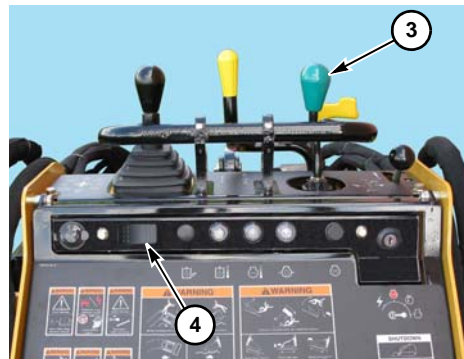
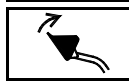

### (4) Auxiliary Flow Speed Selector Switch (Option)

Switch selects flow rate for auxiliary attachment circuit.

5.2 gpm (19.7 L/min) - max flow rate on low setting

13.8 gpm (52.2 L/min) - max flow rate on high setting

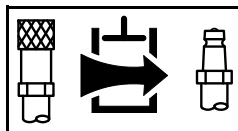

Use low flow setting for functions such as cylinder operation, when a lower speed is desired.



Press left ..... low auxiliary flow rate

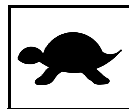

Press right ..... high auxiliary flow rate





## OPERATOR PRESENCE SYSTEM

The Operator Presence system uses a switch in the operator platform to detect the presence of an operator. The operator must be standing on the operator presence foot plate (1) for the ground drive, lift/tilt functions, or auxiliary attachment drive to be engaged.

If the operator leaves the platform while the ground drive, lift/tilt functions, and/or attachment drive are engaged, these functions will stop. If *Lift/Tilt Joystick* is in FLOAT, it will continue to lower/float. The *Auxiliary Attachment Drive Lever* must be returned to OFF before ground drive, lift/tilt, and attachment drive can be re-engaged.

The Operator Presence system is intended for your safety and must be maintained in good functional condition. Contact your Vermeer dealer if it does not function correctly.



## PARK BRAKE

A spring-applied, hydraulic-released park brake engages the left track when the engine is OFF or the operator leaves the platform with the engine on. The brakes will engage within 4" (10 cm) of travel.

## BOOM LIFT/ATTACHMENT TILT LOCKOUT OVERRIDE

In the event of a non-functioning machine, the boom can be lowered and the attachment tilted by turning the ignition key to the RUN position and then moving the Lift/Tilt joystick. In case of a discharged battery, connect jumper battery to the discharged battery posts. Refer to "Jump-Starting Procedure," [page 22-4](#).

## FUSES AND RELAYS

Fuses and relays protect electrical circuits and are located in the engine compartment. Replace fuses with the correct rating to prevent damaging electrical system.

| Fuse Location | Function                                 |
|---------------|--|
| (1) 20A       | Ignition Breaker/All Solenoid Cartridges |
| (2) 20A       | 12 vDC                                   |
| (3) 30A       | Starter Solenoid                         |
| (4) 30A       | Glow Plug                                |
| (5) 15A       | Auxiliary Override                       |
| (6) Open      | Not Used                                 |
| (7) 30A       | Spare                                    |
| (8) 15A       | Spare                                    |
| (9) Open      | Not Used                                 |
| (10) Open     | Not Used                                 |

| Relay Location | Function                |
|----------------|-------------------------|
| (A)            | Operator Presence       |
| (B)            | Operator Presence Latch |
| (C)            | Neutral Start           |
| (D)            | Fuel Shutdown           |

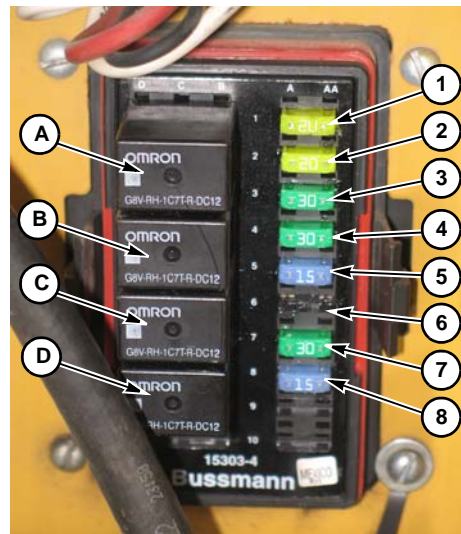

# Section 22: Starting Procedure

## STARTING THE ENGINE

- Step 1:** Stand with both feet on operator platform.
- Step 2:** Move *Ground Drive Joystick* (1) to NEUTRAL.
- Step 3:** Move *Auxiliary Attachment Drive Lever* (2) to NEUTRAL.
- Step 4:** Move *Throttle* (3) to half throttle position.
- Step 5:** If ambient temperature is below 50°F (10°C), turn ignition key (4) to RUN position, then press *Glow Plug Button* and hold for 10–15 seconds. Continue to hold button while starting engine.
- Step 6:** Turn ignition key to START position; release when engine starts.  
If engine does not start within 10 seconds, turn key OFF, wait 30 seconds, then start engine starting sequence over again. Do not allow the starter motor to run continuously for more than 20 seconds.
- Step 7:** Check to see that oil pressure warning light goes off. If not, shut off engine and correct problem.
- Step 8:** Warm up engine at medium speed. Do not operate the engine under load until engine has warmed up.



# COLD WEATHER STARTING

## Engine

Refer to Steps 5 and 6 on previous page, for cold-weather starting.

**NOTICE:** Do not use ether starting aid. Ether may cause engine damage and void engine warranty.

An electric block heater is available from your Vermeer Dealer.

## Hydraulic Fluid

Allow adequate time for hydraulic oil to warm up, especially in cold weather. Refer to the [Specifications](#) section of the [Maintenance Manual](#) for recommended hydraulic fluids.

**NOTICE:** Reduce engine speed if hydraulic pump squeals, indicating lack of oil which can damage the pump.

# JUMP-STARTING

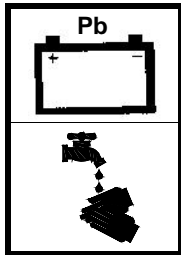

**WARNING:** Battery post, terminals, and related accessories contain lead and lead compounds, chemicals known to the state of California to cause cancer and reproductive harm.

Wash hands after handling.

## Battery Explosion - Avoid

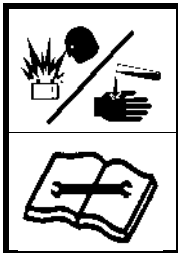

**WARNING:** Battery fumes are flammable and can explode. Keep all burning materials away from battery. Battery explosion can blind. Acid can blind and burn. Tools and cable clamps can make sparks.

Do not smoke. Shield eyes and face. Read instructions.

Do not jump-start or charge a battery that is frozen or low on electrolyte.

Do not allow vehicle used to jump-start to be in contact with the disabled machine. Vehicles in contact have a ground connection which allows a spark to occur at the battery when the positive jumper cable is connected or removed. If equipped with battery caps, they must be in place and tight to reduce risk of battery explosion.

Use only a 12-volt system for jump-starting.

## Battery Burns - Avoid

Battery contains sulfuric acid which can cause severe burns. Avoid contact with eyes, skin, and clothing.

In case of acid contact:

**External:** Flush with plenty of water. If eyes have been exposed, flush with water for 15 minutes and get prompt medical attention.

**Internal:** Drink large quantities of water or milk, follow with milk of magnesia, beaten egg, or vegetable oil. Call a physician immediately.

## Jump-Starting Procedure

**Step 1:** Turn ignition switch to OFF.

**Step 2:** Open engine access door (1).

**Step 3:** Connect jumper cables in the following order:

- a. Red to discharged battery POSITIVE (+) terminal (2).
- b. Red to boost battery POSITIVE (+) terminal (3).
- c. Black to boost battery NEGATIVE (-) terminal (4).
- d. Black to frame (5) of machine with the discharged battery. Make connection away from battery, hydraulic lines, and moving parts.

To avoid sparks, disconnect black cable at point (5) before adjusting red cable at point (2).

**Step 4:** Start engine.

**Step 5:** Remove cables in REVERSE order and install covers over cable clamps. Close and latch battery access shield.

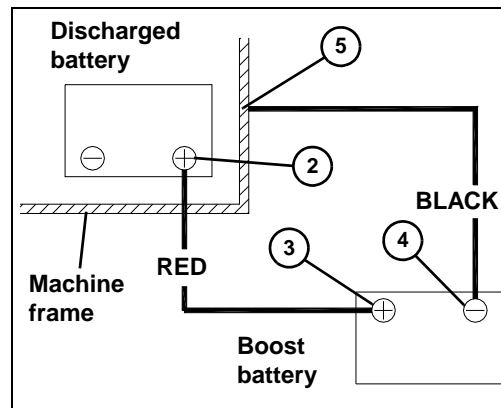
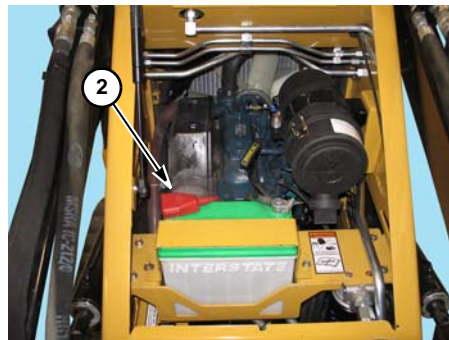
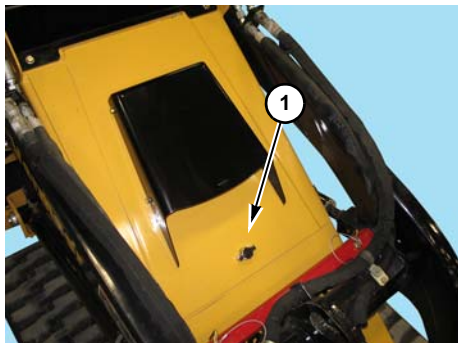

# Section 23: Shutdown Procedure

For your safety and the safety of others, use the shutdown procedure before working on the machine for any reason, including servicing, cleaning, or inspecting the machine.

Park machine on a level surface.

**Step 1:** Move *Ground Drive Joystick* to NEUTRAL.

**Step 2:** Move *Auxiliary Attachment Drive Lever* to OFF.

**Step 3:** Fully lower attachment onto the ground.

**Step 4:** Move *Throttle* to half throttle and run for a minimum of 15 seconds.

**Step 5:** Move *Throttle* fully back to idle.

**Step 6:** Shut off engine and remove key.

A variation of the above procedure may be used if so instructed within this manual or if an emergency requires it.

Park brake will engage when operator steps off platform or engine is shut off and spring-applied park brake pin is aligned between sprocket teeth. The brake will engage within 4" (10 cm) of travel.

This page intentionally left blank.



# Section 30: Transporting the Machine

## LOADING/UNLOADING THE MACHINE



**WARNING:** Machine can slide off loading ramps, or machine can tip over if loaded incorrectly. Serious crushing injury or death can result if struck or crushed by machine. Follow information provided below regarding trailer selection, trailer preparation and loading/unloading.

### Trailer Selection

- Read truck and trailer manual for safety precautions and information.
- Ensure gross weight of the machine, with attachments, is within the weight limits of the trailer and towing vehicle. Refer to the [Maintenance Manual](#) for machine specifications.

### Trailer Preparations

- Trailer bed and ramps must be free of debris that may interfere with loading/unloading.
- Place trailer on a level surface and block wheels or engage park brake of the towing vehicle.
- Do not load if trailer bed or ramps are slippery.
- Excessive ramp angle may increase difficulty in loading/unloading.

## Loading/Unloading

- Back up the ramp while loading, and drive forward down the ramp while unloading when there is a light attachment on the front weighing less than 200 lb (90 kg), such as a standard bucket or forks, or when the attachment has been removed. Driving with operator downhill may result in machine tipping backward.
- Drive forward up the ramp while loading, and back down the ramp while unloading when there is a heavier attachment on the front. Driving with the heavy attachment downhill may result in machine tipping forward.
- Always travel on ramp with attachment as low as practical.
- Never stop or start suddenly while on ramp. Sudden stopping or starting may result in tipping forward or backward. Drive slowly and smoothly while on ramp.
- Avoid steering on ramps. Steering may cause machine to turn suddenly and fall off ramp, or cause ramp to move and fall.
- Position machine and attachments to provide the trailer tongue load recommended by the trailer manufacturer.
- Securely attach loose attachments and machine to trailer.



**WARNING:** Operator's leg can be crushed if machine is moved rearward while standing on the ground. Operator Presence foot plate must function properly. Never attempt to move machine with one or both feet on the ground.



**WARNING:** Machine travel stops if foot platform lifts up during machine travel. Sudden stops from higher travel speeds could throw you from machine, or the machine could tip over. To help avoid sudden stops, keep both feet fully on the platform and stand as far to the rear as practical. Slow down when traveling over uneven ground.

## Driving onto Trailer

Machine is not intended to be driven on public roads.

**Step 1:** Follow *Starting Procedure*, page 22-1.

**Step 2:** Prepare machine to drive onto the trailer. Load and unload machine and attachments in a sequence that does not require you to back off the trailer without an attachment on the machine. Backing down a ramp without an attachment, or with a light attachment, may cause the machine to tip rearward.

**Step 3:** Align machine with trailer ramps, with the heavy end on the uphill side.

**Step 4:** Position loader arms to avoid having to move the attachment while driving on the ramps:

- Before backing onto the ramps, the attachment should be raised so the attachment will not contact the ground as the tracks start up the ramps.
- Before driving forward onto the ramps, the attachment should be raised just enough to prevent the attachment from contacting the ramps.

**Step 5:** Slowly move the machine up the trailer ramps. Minimize steering while on the ramps. Steering while on the ramps may result in the machine driving off the side of the ramps or cause ramps to move and drop off the trailer deck.

**Step 6:** Once the machine is off the ramps and onto the trailer deck, lower the attachment as low as possible.

**Step 7:** Stop machine when tie-down position is reached. Tie-down position distributes machine weight on the trailer as recommended by the trailer manufacturer.

**Step 8:** Lower lift arms and adjust tilt until attachment is firmly on trailer deck.

**Step 9:** Shut off engine and remove key.

**Step 10:** Fasten machine to trailer using front (1) and two rear (2) tie-down points provided on the machine. Attachments that are detached from the loader need to be properly secured for transport.

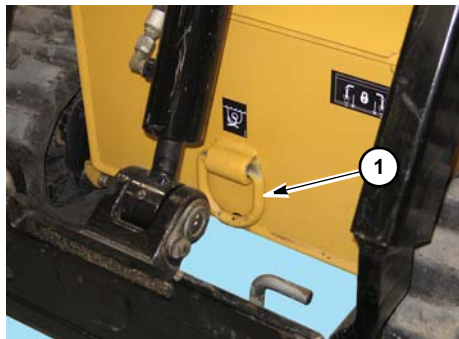

**WARNING:** Attachments could slip off the trailer after being disconnected from the machine, resulting in a crushing injury. When disconnecting and backing the machine away from the side of a trailer, take precautions to assure the attachments are properly secured to the trailer.

## Driving off Trailer

- Step 1:** Remove tie-down straps or chains.
- Step 2:** Follow [Starting Procedure](#), page 22-1.
- Step 3:** Prepare machine to be unloaded.
- Step 4:** Align machine with the trailer ramps, with the heavy end on the uphill side.
- Step 5:** Position loader arms to avoid having to move the attachment while driving down the ramps:
- Before backing down the ramp, the attachment should be raised so the attachment will not contact the ramps as the tracks leave the ramp.
  - Before driving forward down the ramp, the attachment should be raised to prevent the attachment from contacting the ground as the machine reaches the end of the ramps.
- Step 6:** Slowly move machine down the ramp to the ground. Minimize steering while on the ramps. Steering while on the ramps may result in the machine driving off the ramps or cause the ramps to move and drop off the trailer deck.

## Loading with Crane

A lift eye (1) is provided to hoist the machine onto the transport vehicle with a crane. Fully raise lift arms before lifting for proper machine balance.



## TOWING THE MACHINE

Towing requires bypassing the ground drive pump and releasing the park brake.

**Step 1:** Attach a suitable towing chain to front tie-down point (1) or two rear tie-down points (2) to retrieve the machine in the event that the machine becomes mired or disabled.

**Step 2:** Raise loader arms and install support bar. Refer to “Lift Arm Support Bar - Install/Remove,” [page 60-3](#).

**Step 3:** Follow [Shutdown Procedure](#), except leave loader arms raised. Refer to [page 23-1](#).

**Step 4:** Place chocks in front and back of right track.

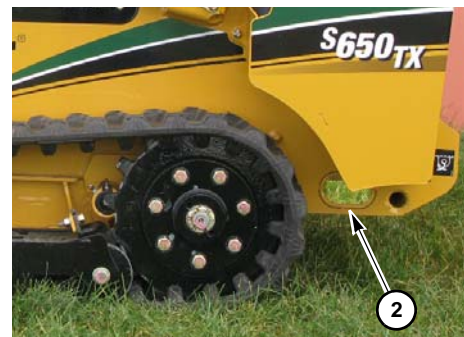
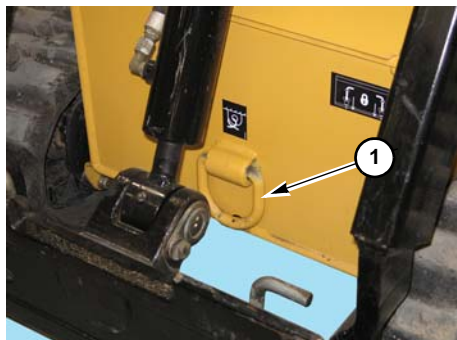

**Step 5:** Open/remove engine shields. Refer to “Shields - Install/Remove,” [page 60-4](#).

**Step 6:** Unscrew two bypass valves (3) located on top of ground drive pumps a maximum of two turns. These valves allow the motors to turn.

**Step 7:** Turn ignition key to RUN position. Refer to “Boom Lift/Attachment Tilt Lockout Override,” [page 21-7](#). Lower loader arms prior to towing.

**Step 8:** Turn ignition key to STOP position.

**Step 9:** To release park brake, loosen jam nut (4), then loosen setscrew (5). Push in pin (6) enough to clear sprocket teeth. Tighten setscrew and jam nut to hold pin in released position. Grease fitting may have to be removed.

**NOTICE:** Machine could roll downhill after park brake is released. If possible, ensure that machine is on a stable and reasonably level surface prior to attempting to retrieve. Proper chocking of tracks is critical to keep machine stationary until ready to tow.

**Step 10:** Move towing vehicle in direction of intended travel to take up slack in towing chain. Carefully remove wheel chocks.

**Step 11:** Tow disabled skid steer to a firm and level surface.

Do not tow more than 100 ft (30 m).

**NOTICE:** The ground speed of the machine must not exceed 1–2 mph (2–3 km/h). Higher speeds will cause heat build-up which will damage the pumps and motors.

**Step 12:** To re-engage park brake, loosen jam nut, then loosen setscrew to free pin. Tighten jam nut to secure setscrew. Ensure pin operates freely after jam nut is tightened.

Pin must align between sprocket teeth to engage park brake. If pin does not engage sprocket teeth by at least 1/2” (13 mm), refer to “Park Brake - Check” in the [Maintenance Manual](#) for instructions.

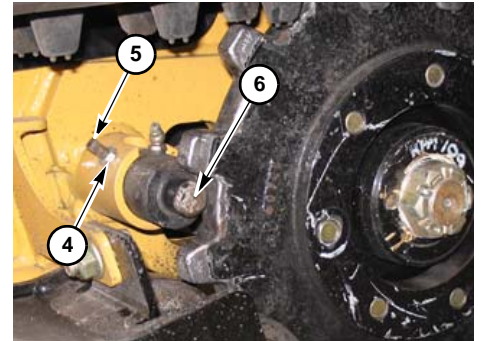
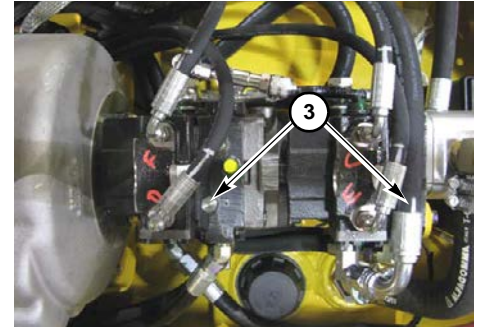

**Step 13:** Tighten bypass valves **(3)** prior to returning unit to service. These valves must be fully closed after towing for normal tractor operation. Torque bypass valves to 15–18 ft-lb (20–25 Nm).

**NOTICE:** Do not attempt to push-start the machine. Damage to ground drive pumps or motors will result if towing instructions are not followed correctly.

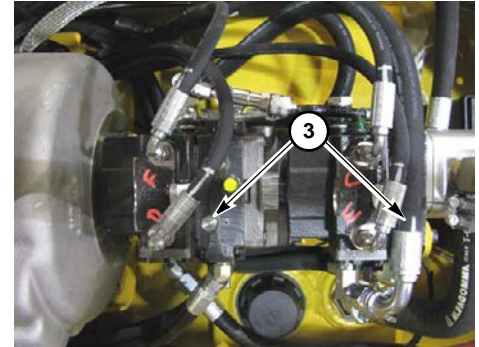

## Clean Machine

**NOTICE:** Machine controls and electrical/electronic devices are not rated to withstand high pressure water and temperature power washers. Water intrusion will likely cause malfunction or damage to any devices hit directly by the water spray. Keep pressure washer stream away from machine controls and electrical/electronic devices. Compressed air can also push moisture through some connector and component seals. Do not point air nozzle directly at seal areas.



# Section 40: Preparation

## OPERATOR QUALIFICATIONS

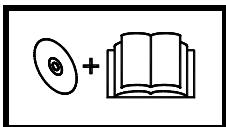

**WARNING:** Read Operator's Manual and safety signs, and watch the operations and safety video, before operating machine.

Allow only responsible, properly instructed individuals to operate machine.

Become familiar with the controls, operation and use of the machine under the supervision of a trained and experienced operator.

The operator must be familiar with the workplace's safety rules and regulations, and must be mentally and physically capable of operating the machine safely.

## PERSONAL PROTECTION



**WARNING:** Wear personal protective equipment. Wear close-fitting clothing and confine long hair. Avoid jewelry, such as rings, wristwatches, necklaces, or bracelets.

---

Operating the machine will require you to wear protective equipment. You should always wear a hard hat, safety shoes, hearing protection, and eye protection. If working near traffic, you may have to wear reflective clothing.

Hearing protection is required when operating the machine. Hearing protection devices provide differing levels of sound reduction. It is important to select a device that is adequate and appropriate for your specific work environment. Actual sound levels may vary widely, depending on your working conditions. To determine the level of hearing protection your work environment requires, enlist the help of your local environmental noise specialist.

Eye protection must consist of wraparound safety glasses or goggles.

Other workers in the immediate area must also wear hard hats, safety shoes, hearing protection, and eye protection.

## SOUND LEVELS

Sound pressure and sound power levels were determined according to test procedures specified in ISO 3744 and ISO 6393 and 6394.

Equivalent Continuous A-Weighted Sound Pressure at Operator's Ear  
as specified by ISO 6394. . . . . 87 dB(A)

Guaranteed Sound Power Level  
as determined by directive 2000/14/EC. . . . . 102 dB(A)

Stated sound levels are representative for a given operating condition. Operating conditions may vary at each site. The actual sound levels for your application and operating conditions may be different.



## VIBRATION LEVELS

Whole body vibration exposure has been measured according to ISO 2631. The level is less than 0.5 m/s<sup>2</sup>.

Hand/arm vibration exposure has been measured according to ISO 5349. The level is less than 2.5 m/s<sup>2</sup>.

## PREPARE THE AREA

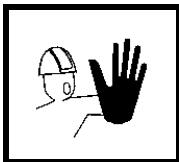

**WARNING:** Keep all spectators and other workers away from the machine and work area while in operation.

---

## Locate Buried Utilities

### Call Your One-Call System First

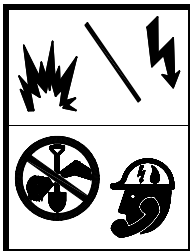

**WARNING:** Electricity or gas explosion can kill. Laser light in cut cable can cause eye damage.

Locate utilities before digging. Call 811 (U.S. only) or 1-888-258-0808 (U.S. or Canada) or local utility companies or national regulating authority.

---

Before you start any digging project, do not forget to call the local One-Call system in your area and any utility company that does not subscribe to the One-Call system. For areas not represented by One-Call Systems International, contact the appropriate utility companies or national regulating authority to locate and mark underground installations. If you do not call, you may have an accident or suffer injuries; cause interruption of services; damage the environment; or experience job delays.

The One-Call representative will notify participating utility companies of your proposed digging activities. Utilities will then mark their underground facilities by using the following international marking codes:

|        |                              |             |                     |
|--------|------------------------------|-------------|---------------------|
| Red    | Electric                     | Green/Brown | Sewer               |
| Yellow | Gas, Oil or Petroleum        | White       | Proposed Excavation |
| Orange | Communication, Telephone, TV | Pink        | Surveying           |
| Blue   | Potable Water                |             |                     |

OSHA CFR 29 1926.651 requires that the estimated location of underground utilities be determined before beginning excavation or underground drilling operation. When actual excavation or bore approaches an estimated utility location, the exact location of the underground installation must be determined by a safe, acceptable and dependable method. If utility cannot be precisely located, it must be shut off by the utility company.

### **Look for Evidence of Underground Placement**

Visually check for:

- notices of underground placements
- manhole covers
- drop boxes
- recent trenching activity

## Striking a Utility

### Electricity

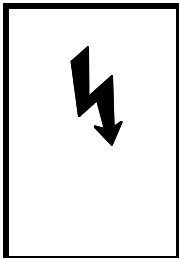

**DANGER:** Electric shock can kill.

If strike occurs, stay on machine. Contacting the machine and ground while stepping off may result in injury or death. Raise auger or trencher to try breaking contact with electric power line. Have someone who is clear of the area contact the utility company to shut off electrical power. Do not continue work until utility company has declared the area safe to resume operation. Do not allow anyone to approach the machine.

Some circuit breakers automatically reset. Do not assume power has been permanently disconnected until you confirm that the utility company has locked out power to that line.

### Gas

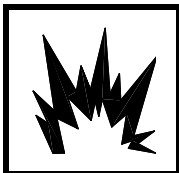

**DANGER:** If you strike a gas line, shut off engine and evacuate area immediately. Contact utility company and do not return until the utility company gives permission to do so.

### Fiber Optic

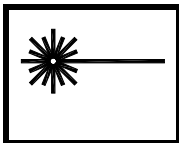

**WARNING:** Laser light may damage eyes. Do not look into the end. Fiber optic cables carry laser light which may damage your eyes. If you are not sure what type of cable it is, do not look into the end. Contact appropriate utility company for assistance.

## Jobsite Assessment

Examine work area for any obstructions, conditions, or situations which may impair machine operation or create a safety hazard for the operator or other persons. Use the information in this manual combined with your own good judgment when identifying these hazards and implementing hazard avoidance measures.

Check for steep slopes, banks, overhangs, drop-offs, and trenches which can cave in.



**WARNING:** The weight of your machine may cause the ground to give way. Machine can fall and tip over. Death or serious injury could result. Keep well away from cliff edges. Do not dig under the machine or attachment. Take care when backfilling. Do not go too close to edges. Do not drive or operate on unstable ground.



**WARNING:** Cliff and high banks can fall on you. Take care when working below overhangs. Do not dig away beneath them. Look out for rock falls and soil slips.

When work is planned inside or around structures such as buildings, bridges, and low-hanging tree limbs, check for adequate overhead and side clearances. Be sure to account for the height of the boom.

The operator or job foreman should also inspect the jobsite for:

- holes, rocks, or other hidden hazards
- traffic/site access

Remove any obstacles or materials that could result in injury or damage the machine.



**WARNING:** Engine exhaust can asphyxiate. If inhaled directly or continuously, the combustion fumes produced by the engine can be very dangerous and/or lethal for the human body. If work has to be done in enclosed environments, take all necessary precautions to ensure the circulation of fresh air and protect the respiratory tract using a suitable mask.

Good ventilation is very important. Sparks from the electrical system and engine exhaust can cause an explosion or fire in a flammable or explosive atmosphere. Do not operate this machine in an area with flammable dust or vapors.

Carbon monoxide fumes from the engine can asphyxiate. Operate only outdoors or provide adequate ventilation if indoor operation is essential.

## PREPARE THE MACHINE

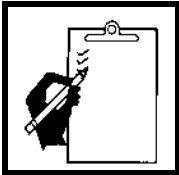

**WARNING:** Check machine before operating. Machine must be in good operating condition and all safety equipment installed and functioning properly.

- Ensure you understand and comply with all jobsite rules that might apply to your work situation.
- If operating along a road, properly warn and divert motor and pedestrian traffic. Use all necessary signs, cones, flag persons, or lighting devices needed for the work situation.



## ATTACHMENTS



**WARNING:** Using attachments authorized by Vermeer Corporation is important for your safety. Using unauthorized attachments may cause difficulties with steering, stopping, stability and other undesirable performance or handling characteristics, or they may not attach securely to your machine. Never use unauthorized attachments.

### Install/Remove

Before connecting any attachment to the machine, ensure all machine and attachment mounting plates are free of dirt and debris in order to ensure the attachment can be properly connected.

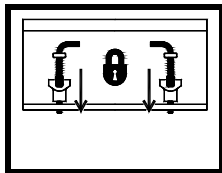

**WARNING:** Attachment can fall off loader attachment mounting plate if incorrectly attached. Serious injury or death could result. When installing attachment, be certain that pins snap into place, pin tops are rotated inward, and pin ends are visible beneath attachment mount.

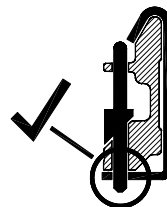

## Attachment - Install

**Step 1:** Position attachment on a level surface with sufficient area behind it to accommodate the machine.

**Step 2:** Ensure pins are rotated so that tops of pins face outward as shown (1).

**Step 3:** Start machine, and lower lift arm. Tilt loader mounting plate forward slightly.

**Step 4:** Drive machine FORWARD, aligning loader mounting plate with attachment.

**Step 5:** Once top edge of mounting plate enters under lip of attachment mount as shown (2), raise lift arm while tilting mounting plate back to securely engage attachment.

**Step 6:** Raise attachment sufficiently to clear the ground. Tilt attachment plate back fully.

**Step 7:** Ensure *Ground Drive* and *Lift/Tilt Controls* are in NEUTRAL, and shut off machine.

**Step 8:** Rotate pins 180° so that pins engage and extend through bottom of attachment mount and are visible beneath attachment mount. Tops of pins must face inward as shown (3).

Ensure pin ends extend through and are visible beneath attachment mount.

**Step 9:** If attachment requires hydraulic power, see “Hydraulics - Attach.” Refer to [page 40-13](#).

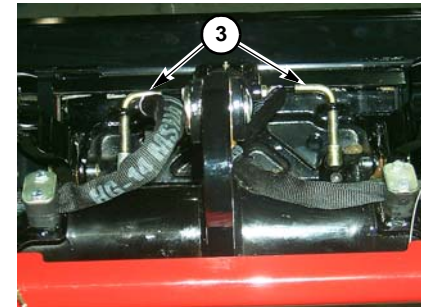
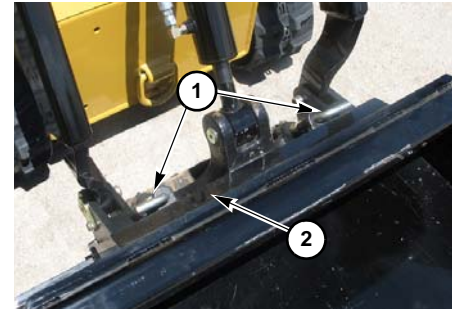
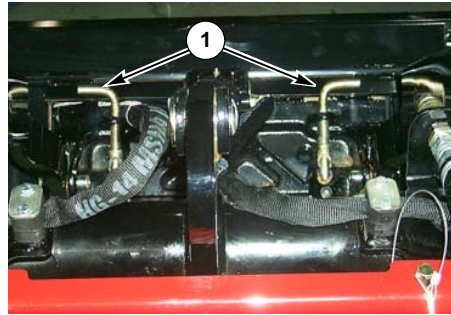

## Attachment - Remove

- Step 1:** If attachment requires hydraulic power, see “Hydraulics - Detach.” Refer to [page 40-13](#).
- Step 2:** Lower loader arms until attachment rests on the ground. Ensure *Ground Drive*, *Auxiliary Drive*, and *Lift/Tilt Controls* are in NEUTRAL, and shut off engine.
- Step 3:** To unlatch attachment, rotate pins (1) 180° so that top of pin faces outward as shown.
- Step 4:** Start engine and tilt loader mounting plate (2) forward slightly. Lower lift arms if necessary.
- Step 5:** Drive machine in REVERSE to detach loader from attachment.

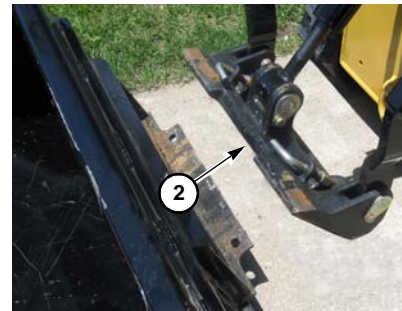
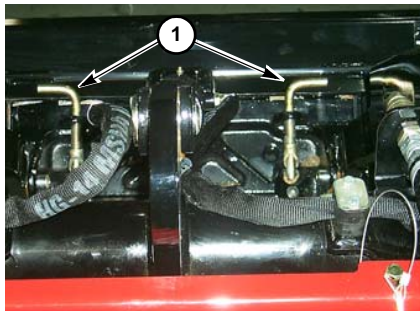

If detaching an attachment onto a trailer with the machine positioned on the ground, locate the attachment to prevent it from falling off.



---

**WARNING:** Attachments could slip off the trailer after being disconnected from the machine, resulting in a crushing injury. When disconnecting and backing the machine away from the side of a trailer, take precautions to assure the attachments are properly secured to the trailer.

---

## HYDRAULICS - ATTACH/DETACH



**WARNING:** Pressurized fluid can penetrate body tissue and result in serious injury or death. Leaks can be invisible. Keep away from any suspected leak. Relieve pressure in the hydraulic system before searching for leaks, disconnecting hoses, or performing any work on the system. If you must pressurize the system to find a suspected leak, use an object such as a piece of wood or cardboard rather than your hands. When loosening a fitting where some residual pressure may exist, slowly loosen the fitting until oil begins to leak. Wait for leaking to stop before disconnecting the fitting. Fluid injected under the skin must be removed immediately by a surgeon familiar with this type of injury.



**WARNING:** Hydraulic couplers, hoses, and fluid may be hot. Contact with hot parts may result in burns. Wear gloves when connecting and disconnecting hydraulic hoses, and wait until unit has cooled before touching hydraulic components.

Ensure all foreign matter is cleaned from hydraulic connectors before making connections.

## Hydraulics - Attach

If attachment requires hydraulic power, after securing attachment to the machine:

- Step 1:** Shut off engine. Move *Auxiliary Attachment Drive Lever* forward, backward, and back to NEUTRAL position to relieve hydraulic pressure.
- Step 2:** Connect hoses to auxiliary hydraulic couplers (1). Confirm that connection is secure by pulling on couplers.

Attachments with cylinders or motors may have residual pressure remaining in hydraulic lines from cylinder or motor loading. Ensure cylinders or motors are not loaded to help relieve residual pressure in attachment hydraulic lines before attaching lines to couplers.

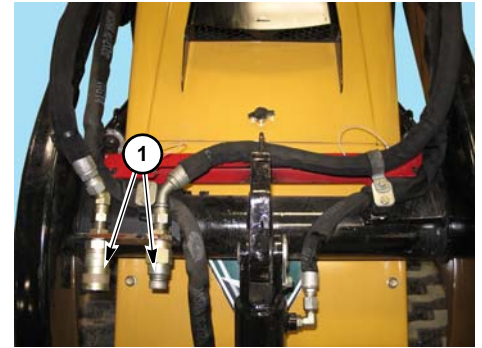

## Hydraulics - Detach

- Step 1:** Lower lift arms until attachment rests on the ground. Ensure *Ground Drive*, *Auxiliary Drive*, and *Lift/Tilt Controls* are in NEUTRAL. Shut off engine.
- Step 2:** Move *Auxiliary Attachment Drive Lever* forward, backward, and back to NEUTRAL position to relieve hydraulic pressure.
- Step 3:** Align pin (2) with notch (3) on female coupler before disconnecting couplers.
- Step 4:** Unhook hoses from auxiliary hydraulic couplers. Remove attachment from machine.



This page intentionally left blank.

# Section 50: Operating the Machine

## LOAD CAPACITIES

The S650TX has a rated operation capacity of 660 lb (300 kg) when tested in accordance with SAE J2752 and ISO 14397-1 standards.

Ensure weight of attachment plus materials being handled does not exceed the machine's operating capacity. Very dense materials weigh more than less dense materials; reduce load size when lifting dense materials. Refer to manuals supplied with attachments for attachment weights.

## DRIVING SAFETY

### Before Driving

Until the operator is familiar with the controls and understands the capability of the machine, use a slower ground speed to move the machine. Use reduced speeds when operating in rough terrain or in confined areas.

A handgrip bar is provided to allow the operator to keep both hands on the bar to securely ride on the machine. Always keep both hands firmly on the handgrip before starting to move the machine. Keep both hands on the grip whenever moving or operating ground drive controls. Return controls to NEUTRAL before removing your hands from the handgrip bar. Before driving or operating the mini skid steer, survey the area around the machine for persons or obstacles.

Place your hands, palms down, on the handgrip bar so your fingers are on the forward area of the bar and the palms on the rear portion of the bar, with the joystick knob cradled between your thumb and forefinger. This provides a secure grip and good lever control.

This machine is not intended to be driven on public roads.

## While Driving

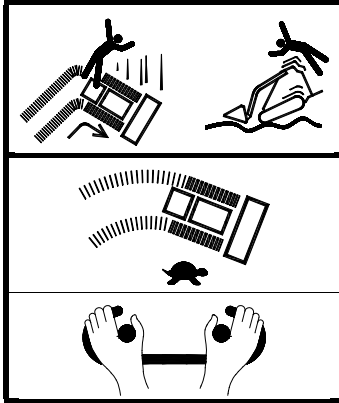

**WARNING:** Abrupt movement and uneven terrain can throw operator off machine.

Avoid abrupt starts, stops, and turns.

Keep both hands firmly on grips.

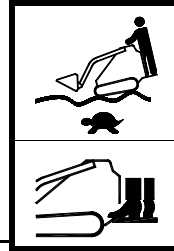

Slow down on rough and uneven terrain.

Keep both feet on platform.

Move *Ground Drive Joystick* slowly to start moving the machine smoothly. Avoid sudden stopping, starting, or turning unless necessary.



**WARNING:** Rider may fall out and be injured or killed.

Do not carry riders.



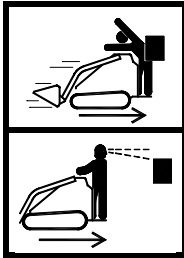

**WARNING:** Objects behind can crush you.

Look behind when moving rearward.

Slow down and use extra caution when traveling around obstructions that may limit visibility.

Drive machine at a speed suitable for the terrain.



**WARNING:** Operator's leg can be crushed if machine is moved rearward while standing on the ground. Operator Presence foot plate must function properly. Never move machine with one or both feet on the ground.

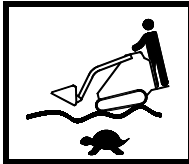

**WARNING:** Machine travel stops suddenly if foot platform lifts up during machine travel. Sudden stops from higher travel speeds could throw you from machine, or the machine could tip over. To help avoid sudden stops, keep both feet fully on the platform and stand as far to the rear as practical. Slow down when traveling over uneven ground.

Operate machine up and down an incline, not across the incline. Use extra care when working on inclines.

When driving over an object such as a curb, the machine can pitch forward or backward quickly. Watch for these objects and travel very slowly. If you will encounter the same object repeatedly, build a ramp with dirt to make traveling smoother.

## Safe Operating on Slopes

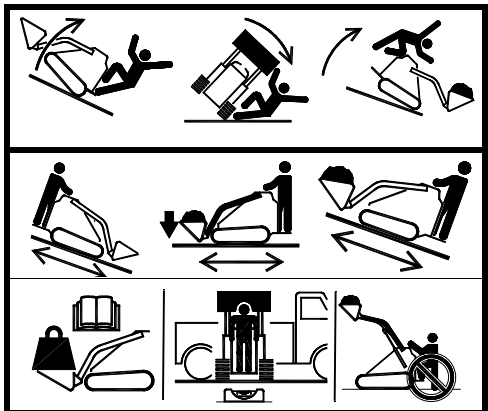

**WARNING:** Traveling on slopes or with load elevated may result in tipover. Serious crushing injury or death can result.

Always travel with load lowered when traveling up or down slopes. You may also need to keep heavy end uphill for added stability.

Do not exceed rated load capacity.  
Load on firm and level ground.  
Do not step off platform with load raised.

Safe operating on slopes depends on several factors including:

- Machine weight distribution including front loading or absence of load
- Height of load
- Even or rough ground conditions
- Potential for ground giving way, causing either unplanned forward, reverse or sideways tilt
- Nearness of ditches, ruts, stumps or other obstructions and sudden changes in slope
- Speed
- Turning
- Braking performance
- Operator skill

These varying factors make it impractical to specify a maximum safe operating angle in this manual. It is therefore important for the operator to be aware of these conditions and adjust operation accordingly. Maximum engine angle and braking performance are two absolute limits which must never be exceeded. These maximums are stated below since they are **design** limits. These angles are not **operating** limits and therefore must never be used alone to establish safe operating angles for varying conditions.

- Maximum engine lubrication angle is 20°
- Service brake retarding force - equal to traction of both tracks
- Secondary brake - equal to traction of one track
- Park brake holding force - equal to traction of one track

## OPERATING THE MINI SKID STEER

Move *Ground Drive Joystick* slowly to start moving the machine smoothly. Avoid sudden stopping, starting, or turning unless necessary. Operate machine up and down an incline, not across the incline. Use extra care when working on inclines.

When driving over an object such as a curb, the machine can pitch forward or backward quickly. Watch for these objects and travel very slowly. If you will encounter the same object repeatedly, build a ramp with dirt to make traveling smoother.

**Step 1:** Follow [Starting Procedure](#), page 22-1.

**Step 2:** Move *Throttle* (1) to desired position.

**Step 3:** Ensure attachment is in transport position (as low as practical and tilted back).

If operator weight is removed from platform, machine hydraulic functions will stop. If attachment *Lift/Tilt Joystick* is in FLOAT, it will continue to lower/float.

**Step 4:** Use *Ground Drive Joystick* (2) to move and steer the machine. Do not jerk control lever. Hold firmly onto handgrip (3) with both hands while operating.

**Step 5:** When parking the machine, always follow shutdown procedure. Follow [Shutdown Procedure](#), page 23-1. Never leave machine with engine running or attachment raised.

The Operator Presence system in the operator platform detects the presence of an operator. The operator must be standing on the platform for the ground drive, lift/tilt functions, or auxiliary attachment drive to be engaged. Keep both feet on the platform.

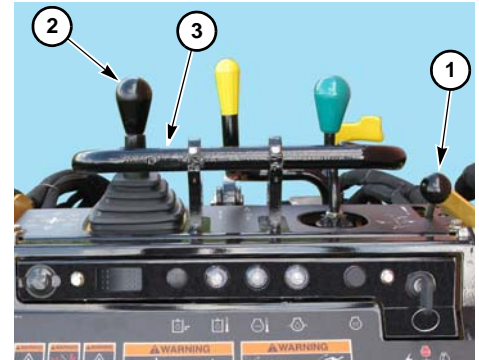

# BUCKET OPERATION

## Bucket - Install/Remove

Follow proper procedures for attaching and removing attachments. Refer to “Attachments,” [page 40-9](#).

### Safety Precautions



**WARNING:** Never work under an attachment unless it is adequately supported to prevent it from falling unexpectedly.



**WARNING:** Falling load can crush.

Keep load level when raising lift arms.

## Moving Machine with Load

- When moving the machine with a full bucket, go up or down slope with load (heavy end of machine) facing top of slope. When moving the machine with an empty bucket, go up or down slope with bucket (light end of machine) facing bottom of slope.
- Keep bucket level and as low as practical (carry position), raised only enough to clear any ground obstructions.
- Watch terrain and avoid slopes, bumps, or depressions which could make machine unstable. Wherever practical, drive directly up or down a slope or curb.
- Do not overload machine. Refer to “Load Capacities,” [page 50-1](#).
- Avoid double stacked loads. Secure any load that could shift during movement.
- Additional safety information is provided in this section. Refer to “Driving Safety,” [page 50-1](#).
- Do not step off operator’s platform when loader arms or attachment are raised. Machine stability is reduced and may cause machine to tip forward when you step off.

## Filling the Bucket

- Step 1: Fully lower lift arms.
- Step 2: Tilt bucket forward until cutting edge of bucket contacts the ground, and bottom of bucket is level with the ground.
- Step 3: Move machine forward slowly into the material while gradually tilting bucket backward as it fills.
- Step 4: Move machine backward away from the material.



**WARNING:** Cliff and high banks can fall on you. Take care when working below overhangs. Do not dig away beneath them. Look out for rock falls and soil slips.

## Digging with the Bucket

- Step 1: Fully lower lift arms.
- Step 2: Tilt bucket forward until cutting edge of bucket contacts the ground.
- Step 3: Move machine forward slowly, continuing to tilt bucket down until it enters the ground to desired depth.
- Step 4: Tilt bucket backward slightly to increase traction and maintain an even digging depth.
- Step 5: Continue driving machine forward until bucket is full.  
If ground is hard, tilt bucket forward and backward while driving slowly forward.
- Step 6: When bucket is full, tilt bucket fully backward.

## Emptying the Bucket

- Step 1:** Move machine with bucket in carry position until dump site is reached.
- Step 2:** Raise bucket just enough to clear side of truck box or bin, while tilting bucket to keep load from spilling. Always load on firm and level ground.
- Step 3:** Move machine forward slowly until the bucket is over the truck box or bin. If possible, avoid steering while load is raised. Steering results in side motion of the load, which could make the machine unstable. If steering is necessary, move very slowly using smooth steering motion.
- Step 4:** Tilt bucket forward until it empties. If necessary, use bucket to redistribute materials in the truck box or bin.
- Step 5:** After dumping load, back away just far enough from truck or container to lower the bucket. Lower bucket before steering. Moving the machine with the bucket raised reduces stability.

## Backdragging with the Bucket

- Step 1:** Push *Lift/Tilt Joystick* fully forward into FLOAT position.
- Step 2:** Tilt bucket down. The farther the bucket is tilted down, the more cutting edge force is applied to move loose material.
- Step 3:** Move machine in reverse to level loose material.
- Step 4:** Before moving forward, raise loader arms or tilt bucket back to lift the bucket cutting edge off the ground.



## Backfilling with the Bucket

- Step 1: Fully lower lift arms.
- Step 2: Use *Lift/Tilt Controls* to tilt bucket forward until cutting edge of bucket contacts the ground.
- Step 3: Move machine forward to the edge of the hole or trench to push material into it.



**WARNING:** The weight of your machine may cause the ground to give way. Machine can fall and tip over. Death or serious injury could result. Keep well away from cliff edges. Take care when backfilling. Do not go too close to edges. Do not drive or operate on unstable ground.

- Step 4: Tilt bucket forward as soon as cutting edge is over the rim of the hole or trench to dump material out of the bucket.
- Step 5: If necessary, raise lift arms and tilt bucket forward to empty the bucket.

## OPERATING WITH OTHER VERMEER-AUTHORIZED ATTACHMENTS

Refer to the attachment manual supplied by the attachment manufacturer for operating and maintenance instructions for the attachment and additional instructions that may be required for the S650TX.

This page intentionally left blank.

# Section 60: Maintenance Intervals

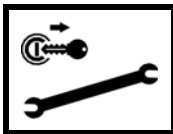

**WARNING:** Before performing any maintenance on the machine, use *Shutdown Procedure*, unless instructed differently in the maintenance sections. Refer to *page 23-1*.

Visually inspect machine daily before starting the machine.

Make no modifications to your equipment unless specifically recommended by Vermeer Corporation.

## SAFETY SIGNS MAINTENANCE

Safety signs located on your machine contain important and useful information that will help you operate your equipment safely. Refer to the *Parts Manual* for locations.

To assure that all safety signs remain in place and in good condition, follow instructions given below:

- Keep safety signs clean. Use soap and water—not mineral spirits, abrasive cleaners, or other similar cleaners that will damage the sign.
- Replace any damaged or missing safety signs. When attaching safety signs, the temperature of the mounting surface must be at least 40°F (5°C). The mounting surface must also be clean and dry.
- When replacing a machine component with a safety sign attached, replace safety sign also.
- Replacement safety signs can be purchased from your Vermeer equipment dealer.

## **MAINTENANCE MANUAL**

Maintenance intervals are included for reference only. Before performing any maintenance, refer to the [Maintenance Manual](#) for safety guidelines and correct procedures.

## **HOURLY METER - CHECK FOR MAINTENANCE INTERVAL**

The hourmeter is used to determine maintenance intervals for the machine. The hourmeter indicates the total number of hours the key has been in RUN position.

Maintenance intervals are based on normal operating conditions. When operating under severe conditions, the maintenance intervals should be shortened.

## **MACHINE - GREASE**

As a general rule, grease machine after it is shut down for the day. This protects metal under seals from corrosion caused by condensation as temperature drops.

Ensure all fittings and nozzle of grease applicator are clean before applying grease. If any grease fittings are missing, replace them immediately.

## **RECOMMENDED FLUIDS**

Refer to the “Specifications” section in the [Maintenance Manual](#) for fluid and lubricant requirements.

## **ENGINE MAINTENANCE INTERVALS**

Refer to the Engine Operation Manual, supplied with each machine, for maintenance instructions that are not included in this manual.

## LIFT ARM SUPPORT BAR - INSTALL/REMOVE

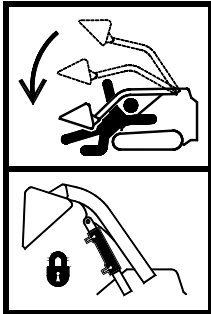

**WARNING:** Falling loader arms can crush.

Engage lock bar before working under arms.

Always empty or remove attachment and install loader arm support bar before working beneath raised loader arms.

- Step 1:** Remove pins (1) and red support bar (2) from stow location shown in top photo.
- Step 2:** Install support bar over lift arm cylinder as shown in bottom photo. Secure with pins in two outer holes (3).
- Step 3:** When work is finished, return support bar to stow location. Install pins in two inner holes.

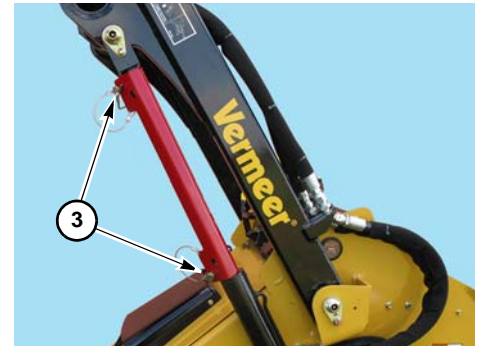
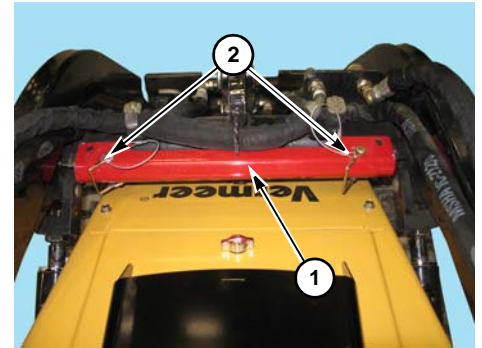

## SHIELDS - INSTALL/REMOVE

- Step 1:** With loader arms raised and supported, turn latch (1) and open engine shield (2).
- Step 2:** Remove six bolts (circled). Remove lower access shield (3).
- Step 3:** Remove three bolts (4). Remove side shield (one shield on each side of machine).
- Step 4:** Reverse procedure to install shields.

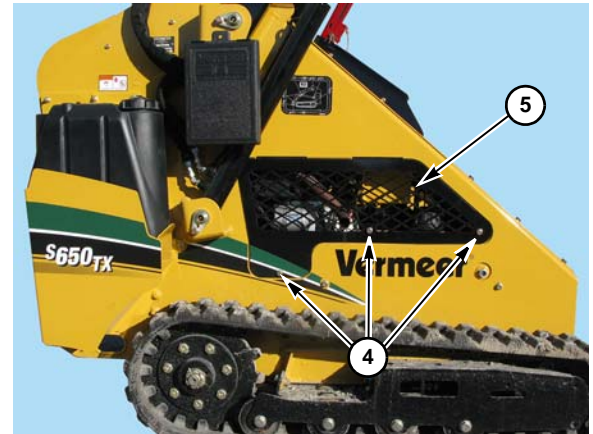
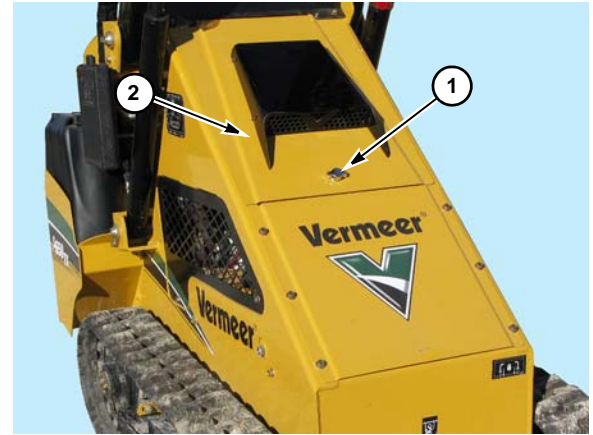

# MAINTENANCE INTERVAL SCHEDULE

Initial = Initial maintenance on new machine. Regular maintenance interval may be different.

● = Regular maintenance interval.

For Vermeer maintenance replacement part numbers, refer to the [Parts Manual](#) or call your Vermeer dealer

|   | 10 Hrs<br>Day | 50 Hrs<br>Week | 100 Hrs<br>Month | 150<br>Hours | 200<br>Hours | 250<br>Hours | 500<br>Hours | 1000<br>Hours | As<br>Needed |
|---|---------------|----------------|------------------|--------------|--------------|--------------|--------------|---------------|--------------|
| Engine Coolant Level - Check              | ●             |                |                  |              |              |              |              |               |              |
| Engine Oil - Check                        | ●             |                |                  |              |              |              |              |               |              |
| Fuel Tanks - Fill                         | ●             |                |                  |              |              |              |              |               |              |
| Hydraulic Fluid - Check                   | ●             |                |                  |              |              |              |              |               |              |
| Air Cleaner - Check/Service               | ●             |                |                  |              |              |              |              |               |              |
| Attachment Plate - Grease                 | ●             |                |                  |              |              |              |              |               |              |
| Boom - Grease                             | ●             |                |                  |              |              |              |              |               |              |
| Park Brake - Grease                       | ●             |                |                  |              |              |              |              |               |              |
| Fuel Lines and Clamp Bands<br>- Check     |               | ●              |                  |              |              |              |              |               |              |
| Engine Oil and Filter -<br>Change/Replace |               | Initial        |                  |              |              |              |              |               |              |
| Hydraulic Filter -<br>Replacement         |               | Initial        |                  |              |              |              |              |               |              |
| Track Tension - Check                     |               | ●              |                  |              |              |              |              |               |              |
| Fan Belt Tightness - Check                |               |                | ●                |              |              |              |              |               |              |
| Machine - Overall Check                   |               |                | ●                |              |              |              |              |               |              |
| Neutral Start Interlocks -<br>Check       |               |                | ●                |              |              |              |              |               |              |

|  | 10 Hrs<br>Day | 50 Hrs<br>Week | 100 Hrs<br>Month | 150<br>Hours | 200<br>Hours | 250<br>Hours | 500<br>Hours | 1000<br>Hours | As<br>Needed |
|--|---------------|----------------|------------------|--------------|--------------|--------------|--------------|---------------|--------------|
| Park Brake - Check                           |               |                | ●                |              |              |              |              |               |              |
| Operator Presence System -<br>Check          |               |                | ●                |              |              |              |              |               |              |
| Safety Signs Maintenance                     |               |                | ●                |              |              |              |              |               |              |
| Hydraulic System - Check                     |               |                | ●                |              |              |              |              |               |              |
| Engine Oil and Filter -<br>Change/Replace    |               |                |                  | ●            |              |              |              |               |              |
| Radiator Hoses and Clamps -<br>Check         |               |                |                  |              | ●            |              |              |               |              |
| Hydraulic Oil Cooling Fan -<br>Check/Service |               |                |                  |              | ●            |              |              |               |              |
| Hydraulic Filter - Replace                   |               |                |                  |              |              | ●            |              |               |              |
| Fuel Tanks Sediment -<br>Remove              |               |                |                  |              |              |              | ●            |               |              |
| Fan Belt - Replace                           |               |                |                  |              |              |              | ●            |               |              |
| Radiator - Drain and Refill                  |               |                |                  |              |              |              | ●            |               |              |
| Battery Terminals - Check/<br>Clean          |               |                |                  |              |              |              | ●            |               |              |
| Hydraulic Fluid - Change                     |               |                |                  |              |              |              |              | ●             |              |
| Hydraulic Strainer - Service                 |               |                |                  |              |              |              |              | ●             |              |
| Engine System - Check                        |               |                |                  |              |              |              |              |               | ●            |
| Lift Arm Cylinders - Adjust                  |               |                |                  |              |              |              |              |               | ●            |
| Air Cleaner Element -<br>Replace             |               |                |                  |              |              |              |              |               | ●            |
| Battery - Replace                            |               |                |                  |              |              |              |              |               | ●            |
| Handgrip Bar - Adjust                        |               |                |                  |              |              |              |              |               | ●            |



|                        | 10 Hrs<br>Day | 50 Hrs<br>Week | 100 Hrs<br>Month | 150<br>Hours | 200<br>Hours | 250<br>Hours | 500<br>Hours | 1000<br>Hours | As<br>Needed |
|------------------------|---------------|----------------|------------------|--------------|--------------|--------------|--------------|---------------|--------------|
| Track Tension - Adjust |               |                |                  |              |              |              |              |               | ●            |
| Storage                |               |                |                  |              |              |              |              |               | ●            |

## ATTACHMENT MAINTENANCE

Refer to the attachment manuals provided by the attachment manufacturer. The attachment manuals must be attached to the machine together with the S650TX [Operator's Manual](#).

This page intentionally left blank.

# Index

## A

Attachment - Install, 40-10  
Attachment - Remove, 40-11  
Attachment Maintenance, 60-7  
Attachments, 40-9

## B

Backdragging with the Bucket, 50-10  
Backfilling with the Bucket, 50-11  
Battery Burns - Avoid, 22-3  
Battery Explosion - Avoid, 22-3  
Before Driving, 50-1  
Boom Lift/Attachment Tilt Lockout Override, 21-7  
Bucket - Install/Remove, 50-7  
Bucket Operation, 50-7

## C

Call Your One-Call System First, 40-4  
Clean Machine, 30-8  
Cold Weather Starting, 22-2  
Control Station, 21-4  
Controls, 21-1  
Crystalline Silica, 10-6

## D

Dealer Prep, i  
Dealer/Customer Information, iii  
Delivery, ii

**S650TX Mini Skid Steer**

Digging with the Bucket, 50-9  
Driving off Trailer, 30-5  
Driving onto Trailer, 30-3  
Driving Safety, 50-1

## E

Electricity, 40-6  
Emptying the Bucket, 50-10  
Engine Controls, 21-1  
Engine Maintenance Intervals, 60-2  
Engine, 22-2

## F

Fiber Optic, 40-6  
Filling the Bucket, 50-9  
Fuses and Relays, 21-8

## G

Gas, 40-6

## H

Hourmeter - Check for Maintenance Interval, 60-2  
Hydraulic Fluid, 22-2  
Hydraulics - Attach, 40-13  
Hydraulics - Attach/Detach, 40-12  
Hydraulics - Detach, 40-13

**Index**

## **I**

Identification Decals, v  
Identification Numbers - Record, iv  
Indicator Lights, 21-3  
Install/Remove, 40-9  
Intended Use, 20-1

## **J**

Jobsite Assessment, 40-7  
Jump-Starting Procedure, 22-4  
Jump-Starting, 22-2

## **K**

## **L**

Lift Arm Support Bar - Install/Remove, 60-3  
Load Capacities, 50-1  
Loading with Crane, 30-6  
Loading/Unloading the Machine, 30-1  
Loading/Unloading, 30-2  
Locate Buried Utilities, 40-4  
Look for Evidence of Underground Placement, 40-5

## **M**

Machine - Grease, 60-2  
Maintenance Interval Schedule, 60-5  
Maintenance Intervals, 60-1  
Maintenance Manual, 60-2  
Moving Machine with Load, 50-8

## **N**

## **O**

Operating the Machine, 50-1  
Operating the Mini Skid Steer, 50-6  
Operating with Other Vermeer-Authorized Attachments, 50-11  
Operator Presence System, 21-7  
Operator Qualifications, 40-1

## **P**

Park Brake, 21-7  
Personal Protection, 40-2  
Preparation, 40-1  
Prepare the Area, 40-4  
Prepare the Machine, 40-8

## **Q**

## **R**

Receiving and Delivery Report, i  
Recommended Fluids, 60-2

## **S**

Safe Operating on Slopes, 50-4  
Safety Messages, 10-1  
Safety Precautions, 50-7  
Safety Signs Maintenance, 60-1  
Safety Symbol Explanation, 10-2  
Shields - Install/Remove, 60-4  
Shutdown Procedure, 23-1  
Sound Levels, 40-3  
Starting Procedure, 22-1  
Starting the Engine, 22-1  
Striking a Utility, 40-6

## **T**

Towing the Machine, 30-6

Trailer Preparations, 30-1

Trailer Selection, 30-1

Transporting the Machine, 30-1

## **U**

## **V**

Vibration Levels, 40-3

## **W**

While Driving, 50-2

**This page intentionally left blank.**

# Revision History

| Revision | Date  | Pages                     | Description  |
|----------|-------|---------------------------|--|
| o1_00    | 09/11 | All                       | First edition Operator's Manual released.  |
| o1_01    | 02/12 | Introduction              | Added warranty rider, sound levels.  |
| o1_02    | 01/13 | Sections: R&D, 20, 40, 60 | Identification decals, auxiliary lever design, <i>Auxiliary Flow Speed Selector Switch (Option)</i> , Shields - Install/Remove, maintenance intervals, miscellaneous updates |
|          |       |                           |  |
|          |       |                           |  |
|          |       |                           |  |
|          |       |                           |  |
|          |       |                           |  |
|          |       |                           |  |
|          |       |                           |  |
|          |       |                           |  |
|          |       |                           |  |
|          |       |                           |  |
|          |       |                           |  |
|          |       |                           |  |
|          |       |                           |  |
|          |       |                           |  |
|          |       |                           |  |



## **WARNING**

**The engine exhaust from this product contains chemicals known to the State of California to cause cancer, birth defects, or other reproductive harm.**

## **CALIFORNIA**

### **Proposition 65 Warning**

**Diesel engine exhaust and some of its constituents are known to the State of California to cause cancer, birth defects, and other reproductive harm.**

**When operated in California, any off-road diesel vehicle may be subject to the California Air Resources Board In-Use Off-Road Diesel Vehicle Regulation. It therefore could be subject to retrofit or accelerated turnover requirements to reduce emissions of air pollutants. For more information, please visit the California Air Resources Board website at <http://www.arb.ca.gov/msprog/ordiesel/ordiesel.htm>.**